

Mini-PC in H7 style for the second Intel Core i3/i5/i7 generation

With an established reputation as the pioneer in the Mini-PC sector, Shuttle introduces an innovative XPC Barebone for Intel's latest "Sandy Bridge" platform. The SH67H3 supports Intel Core i3 / i5 / i7 processors with 1155 socket and up to 32 GB DDR3 RAM, split between four slots. The PCIe-x16 slot of the SH67H3 also accommodates large dual-slot graphics cards. Alternatively, the CPU-integrated graphics function*) can be used. Multi-monitoring is also possible thanks to the two digital HDMI and DVI monitor connections. The SH67H3 also comes with an array of ports including 4x USB 3.0, 4x USB 2.0, 2x eSATA and S/PDIF available on the front and rear panels. This attractive aluminium package is rounded off with Gigabit LAN and an effective heatpipe cooling system.

*) Integrated graphics dependent on processor type

XPC Barebone SH67H7



Images for illustration purposes only.

Feature Highlights

| | |
|--------------------------------------|---|
| H7 chassis | <ul style="list-style-type: none"> Black aluminium chassis (12.8 litre) Bays: 1x 5.25" external, 2x 3.5" int./ext. |
| CPU | <ul style="list-style-type: none"> Supports Socket 1155 Desktop CPUs Supports Intel Core i3 / i5 / i7 (TDP ≤95W) Shuttle I.C.E. Heat-pipe cooling system |
| Slots | <ul style="list-style-type: none"> 1x PCIe x16 (v2.0) supports dual-slot PCE-Express X16 graphics cards 1x PCIe x1 (v2.0), 1x Mini-PCIe x1 (v2.0) |
| Chipset | <ul style="list-style-type: none"> Intel H67 Express PCH |
| Optional: Integrated Graphics | <ul style="list-style-type: none"> Intel HD graphics integrated in the Intel Core i3/i5/i7 processor (depends on processor typ) Output: HDMI 1.4a and DVI-I Supports HDCP, 1080p Full-HD |
| Memory | <ul style="list-style-type: none"> Supports 4x DDR3-1066/1333 Up to 32 GBytes total size (4x 8 GB) |
| Drive connectors | <ul style="list-style-type: none"> 2x SATA 6Gb/s and 2x SATA 3Gb/s, RAID 2x External SATA 3Gb/s (front and rear) |
| Other connectors | <ul style="list-style-type: none"> 7.1-ch HD-audio, SPDIF output GigaBit LAN (RJ45) 4x USB 3.0 (2x front, 2x rear) 7x USB 2.0 (1x front, 4x rear, 2x onboard) optional: RS232 COM-Port |
| Power supply | <ul style="list-style-type: none"> 300 Watt power supply (80 PLUS Bronze) |
| Application | <ul style="list-style-type: none"> Home-Media |



Shuttle XPC Barebone SH67H7 – Special Product Features



The H7 chassis design: a clean and modern look

Shuttle has always placed great emphasis on the interior and exterior aesthetics of the XPC, with the belief that a good blend of style and form factor allows the XPC to be attractive, versatile, and work well in almost any environment. The chassis and case cover are made of aluminium and come with a sleek brushed metal front fascia. The drives and front panel connectors are elegantly hidden by drive doors for superior style and visual appeal.

Small, but easy to install

Shuttle XPCs offer the performance of a desktop PC at a third of the size while using standard desktop components. Shuttle keeps the concept of being "futureproof" in mind when designing the new H7 chassis. The meticulously designed internal layout features pre-routed cables to reduce clutter, increase airflow and make the installation of components easy.

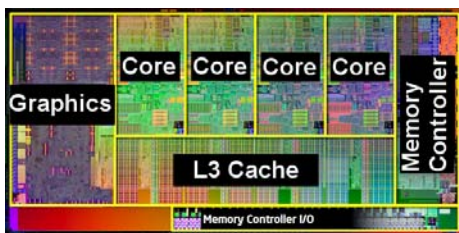

*) Integrated graphics dependent on processor type

Supports the Intel 32nm Sandy Bridge Processor

Sandy Bridge is the codename for Intel's new 32nm processor microarchitecture introduced in early 2011. It is the most sweeping architectural transition from Intel since the introduction of Pentium 4. In addition to two or four CPU cores, the design incorporates the memory controller, PCIe links and the graphics processor *). This integration brings higher performance, lower platform power consumption and more compact packaging. The integrated graphics processor (IGP) has become more capable. It can decode and encode H.264 high-definition video streams. The architecture provides a high-bandwidth, ring-style interconnect between the cores with their associated L3 cache partitions and the IGP. This also allows the IGP to expand its available bandwidth by making use of the L3 cache.



2nd Generation Intel Core processor family

The new "Sandy Bridge" processors with Socket 1155 follows the same naming system as its predecessor "Nehalem" with Socket 1156, but are not downward compatible. Please refer to the support list for detailed processor support information at global.shuttle.com.

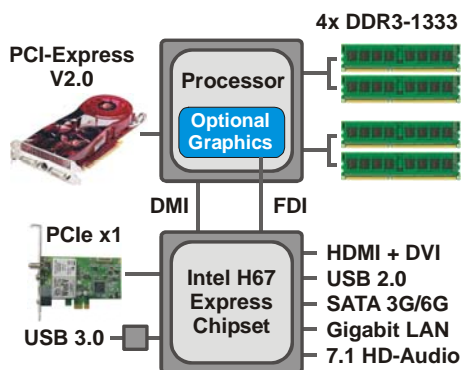

Single-Chip Chipset: Intel H67 Express

The design of the Core i3/i5/i7 processors will eliminate the need for the traditional Northbridge found on previous generation mainboards. Thus the Shuttle XPC Barebone SH67H7 sports Intel's H67 Express Platform Controller Hub (PCH) from the Intel 6-Series "Cougar Point" family which integrates the hard drive controller, network controllers, monitor and physical interfaces, PCIe links and other input/output functionalities.



Integrated Cooling Engine (I.C.E.)

Shuttle XPCs offer the performance of a desktop PC at a third of the size. In order to ensure proper airflow inside such a small case, more advanced cooling technologies have been developed and implemented in the Shuttle XPC. Shuttle's industry-leading I.C.E. heatpipe technology delivers efficient cooling and is exceptionally quiet.



What is a Barebone?

The Shuttle XPC Barebone SH67H7 consists of a stylish case with pre-installed mainboard, power supply unit (PSU) and cables. Despite its small form factor it offers outstanding connectivity, functionality and performance. For a full PC system, at least a processor, memory, hard disk and operating system need to be added. Shuttle XPC Barebones are completely customizable meaning users can pick certain components on their own to ideally match their individual needs.



4x USB 3.0

The Shuttle XPC Barebone SH67H7 sports four USB 3.0 ports (2x front, 2x rear) besides five USB 2.0 ports. USB 3.0 achieves a maximum data rate of up to 5.0Gbps (640MBytes/sec) which is ten times faster than USB 2.0. USB 3.0 is fully compatible to USB 2.0, but not to USB 1.1. At a glance, USB 3.0 connectors seem no different to USB 2.0 connectors, however USB 3.0 connectors have 5 more pins placed inside the connector itself. USB 2.0 can provide a maximum of 500mA power to the USB device while USB 3.0 can provide a maximum output of 900mA, which is important for portable hard drives. USB 3.0 also comes with better power saving features to let your devices consume less power when in idle mode.



SATA 3.0 with up to 6 Gbit/s speed

The Shuttle XPC Barebone SH67H7 has two onboard Serial ATA ports Revision 3.0 delivering super-fast 6Gbps link speeds for twice the data transfer rates of SATA Revision 2.0 (3 Gbps). A move from SATA 3 Gbit/s to SATA 6 Gbit/s allows the new generation of Solid-State Drives (SSDs) to work at their full speed. As for standard hard disks (HDDs), reading times from their built-in DRAM cache will be faster too..



PCI-Express V2.0 for high-performance graphics cards

The Shuttle XPC Barebone SH67H7 is equipped with one PCI-Express x16 Version 2.0 slot delivering a bandwidth of up to 16GB/s which is twice the speed of PCI-E 1.0. So there is plenty of potential for the newest graphics cards. It is downward compatible, allowing for use of most of the present graphics cards as well.



Supports Dual-Slot Graphics Cards

Despite the small housing, the SH67H7 is capable of running dual-slot (double-height) PCI Express graphics cards. Please refer to the support list for detailed support information. Note that the integrated graphics will be disabled when using a discrete graphics card.



Supports one optical drive and two hard disks

Furthermore, users can install one optical drive and up to two hard disks into the SH67H7. But what about heat? Many of the clever design elements of the XPC get little attention. For example, the drive rack built into the SH67H7 leaves space between the hard disks to improve air flow. Intelligently-engineered airflow mechanics channels cool air to where it's needed most - protecting components and providing optimal performance.



HD Audio capabilities

The Shuttle XPC Barebone SH67H7 supports 7.1 channel audio via four analog stereo audio ports or the optical S/PDIF out. In addition, HDMI combines high bandwidth video with digital audio in a single port. It supports up to 8 channels of uncompressed audio at sample sizes of 16-bit, 20-bit, and 24-bit, with sample rates of 32 kHz, 44.1 kHz, 48 kHz, 88.2 kHz, 96 kHz, 176.4 kHz, and 192 kHz. HDMI also supports such as Dolby Digital and DTS, lossless compressed audio streams Dolby TrueHD and DTS-HD Master Audio.



80 PLUS BRONZE certified Power Supply

The Shuttle XPC Barebone SH67H7 is equipped with a rock stable 300W power supply which has been tested with some of the latest graphics cards and powerful Core i3/i5/i7 processors. Its 80 Plus Bronze logo indicates that it provides more than 82/85/82% of energy efficiency at 20/50/100% of rated load which reduces energy consumption and increases the computer's reliability. In addition, the power supply uses a 50mm cooling fan providing the same airflow, but spins slower than previous 40mm models to make the system run even more quietly.



Supports up to 32 GB of memory

The Shuttle XPC Barebone SH67H7 supports up to 32 GB DDR3-1333 memory which is ideal for workstations powered by 64-bit operating systems, enabling users to take full advantage of high-performance configurations.



External Serial ATA (eSATA)

eSATA bears the following advantages:

- + Up to six times faster than USB 2.0/Firewire
- + Robust and user-friendly external connector
- + High-performance, cost-effective expansion storage
- + Up to two meter shielded cables and connectors



Optional: serial RS-232 port (COM)

As an option, you can install one serial COM port (RS232) in the back panel. Today, many consumer PCs do no longer have this legacy port, since that interface has been superseded by USB. Still, they are commonly used for applications of industrial automation systems, scientific analysis, and POS systems.

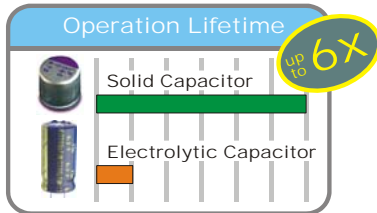

Solid Capacitors

By using all-solid capacitors (except the audio part) Shuttle mainboards are long-life and provide industry leading stability and reliability. The average lifespan of one solid capacitor is more than six times greater than the more common and less expensive electrolytic capacitors.

Shuttle SH67 series with two chassis designs

SH67H3

Open front



SH67H7

With front doors



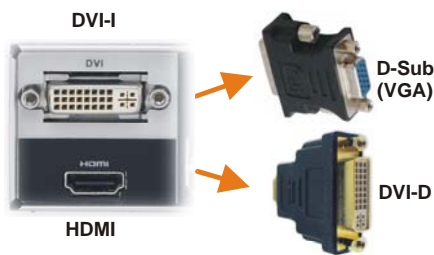

Built-in Intel® HD Graphics Engine *)

The Intel GMA HD 3000 / 2000 graphics processor has been moved onto the same die as the CPU. It supports HDMI 1.4a standard with 3D stereoscopic playback, hardware encoding for H.264 and MPEG-2 video, full 1080p high-definition video playback - including Blu-ray disc movies, DirectX 10.1 and Shader 4.1. HD 2000 has 6 execution units (similar to shader/stream processors) while HD 3000 has 12, the latter is only available on the "K" series, though the i7's allow for a higher maximum dynamic graphics frequency. With all these improvements and changes to the architecture, this GPU is comparable to entry level discrete cards like AMD Radeon HD 5450.

Video output options *)

With optional adapters (not included) DVI-D devices can be connected to the HDMI port or VGA devices to the DVI-I port, respectively.

DVI-D means the connector only outputs digital video signals. **DVI-I** means digital and analog video signals are put out. **HDMI** supports digital video plus multi-channel digital audio output.

Dual View Technology with HDMI and DVI (or VGA) *)

Dual View technology offers multiple display support on up to two separate monitors. This help to improve on productivity by allowing to spread multiple windows across two monitors while working with them simultaneously. SH67H7 features two video outputs: HDMI and DVI-I.

Supports 4 displays with additional graphics card *)

With Shuttle SH67H7 the user can support 4 displays in combination with a discrete PCI-Express graphics card, when the initial display is connected to the integrated graphics. For this, you have to enter the BIOS Setup Utility by pressing the "Delete" key after power on the PC. In the "Advanced" BIOS menu please set "Initiate Graphic Adapter" to "Onboard VGA". The Windows Device Manager will show the integrated graphics and the external discrete graphics card as well. Note, that the graphics performance is limited to the integrated graphics engine. This function is based on the Switchable Graphics feature of the 2nd Generation Intel® Core™ Processors with Intel® HD Graphics.

*) Certain processor models do not include the integrated graphics, e.g. Intel Core i5-2380P, Core i5-2450P and Core i5-2550K.

Socket 1155 processor overview (January 2011)

| Name | Model | Cores | HT | Clock | Turbo | Cache | TDP | Graphics | Graphics clock |
|---------|-------|-------|---------|---------|---------|-------|-----|----------|----------------|
| Celeron | G440 | 1 | - | 1.6 GHz | - | 1 MB | 35W | HD | 650~1000 MHz |
| | G460 | 1 | - | 1.8 GHz | - | 1 MB | 35W | HD | 650~1000 MHz |
| | G530 | 2 | - | 2.4 GHz | - | 2 MB | 65W | HD | 850~1000 MHz |
| | G530T | 2 | - | 2.0 GHz | - | 2 MB | 35W | HD | 650~1100 MHz |
| | G540 | 2 | - | 2.5 GHz | - | 2 MB | 65W | HD | 850~1000 MHz |
| Pentium | G620T | 2 | - | 2.2 GHz | - | 3 MB | 35W | HD | 650~1100 MHz |
| | G620 | 2 | - | 2.6 GHz | - | 3 MB | 65W | HD | 850~1100 MHz |
| | G630 | 2 | - | 2.7 GHz | - | 3 MB | 65W | HD | 850~1100 MHz |
| | G630T | 2 | - | 2.3 GHz | - | 3 MB | 35W | HD | 650~1100 MHz |
| | G840 | 2 | - | 2.8 GHz | - | 3 MB | 65W | HD | 850~1100 MHz |
| | G850 | 2 | - | 2.9 GHz | - | 3 MB | 65W | HD | 850~1100 MHz |
| | G860 | 2 | - | 3.0 GHz | - | 3 MB | 65W | HD | 850~1100 MHz |
| Core i3 | 2100T | 2 | Yes | 2.5 GHz | - | 3 MB | 35W | HD 2000 | 650~1100 MHz |
| | 2100 | 2 | Yes | 3.1 GHz | - | 3 MB | 45W | HD 2000 | 850~1100 MHz |
| | 2105 | 2 | Yes | 3.1 GHz | - | 3 MB | 45W | HD 3000 | 850~1100 MHz |
| | 2120 | 2 | Yes | 3.3 GHz | - | 3 MB | 45W | HD 2000 | 850~1100 MHz |
| | 2120T | 2 | Yes | 2.6 GHz | - | 3 MB | 35W | HD 2000 | 650~1100 MHz |
| | 2125 | 2 | Yes | 3.3 GHz | - | 3 MB | 65W | HD 3000 | 850~1100 MHz |
| | 2130 | 2 | Yes | 3.4 GHz | - | 3 MB | 65W | HD 2000 | 850~1100 MHz |
| Core i5 | 2390T | 2 | Yes | 2.7 GHz | 3.5 GHz | 3 MB | 35W | HD 2000 | 650~1100 MHz |
| | 2300 | 4 | - | 2.8 GHz | 3.1 GHz | 6 MB | 95W | HD 2000 | 850~1100 MHz |
| | 2310 | 4 | - | 2.9 GHz | 3.2 GHz | 6 MB | 95W | HD 2000 | 850~1100 MHz |
| | 2320 | 4 | - | 3.0 GHz | 3.3 GHz | 6 MB | 95W | HD 2000 | 850~1100 MHz |
| | 2380P | 4 | - | 3.1 GHz | 3.4 GHz | 6 MB | 95W | - | - |
| | 2400S | 4 | - | 2.5 GHz | 3.3 GHz | 6 MB | 65W | HD 2000 | 850~1100 MHz |
| | 2405S | 4 | - | 2.5 GHz | 3.3 GHz | 6 MB | 65W | HD 3000 | 850~1100 MHz |
| | 2400 | 4 | - | 3.1 GHz | 3.4 GHz | 6 MB | 95W | HD 2000 | 850~1100 MHz |
| | 2450P | 4 | - | 3.2 GHz | 3.5 GHz | 6 MB | 95W | - | - |
| | 2500T | 4 | - | 2.3 GHz | 3.3 GHz | 6 MB | 45W | HD 2000 | 650~1250 MHz |
| | 2500S | 4 | - | 2.7 GHz | 3.7 GHz | 6 MB | 65W | HD 2000 | 850~1100 MHz |
| | 2500 | 4 | - | 3.3 GHz | 3.7 GHz | 6 MB | 95W | HD 2000 | 850~1100 MHz |
| | 2500K | 4 | - | 3.3 GHz | 3.7 GHz | 6 MB | 95W | HD 3000 | 850~1100 MHz |
| 2550K | 4 | - | 3.5 GHz | 3.8 GHz | 6 MB | 95W | - | - | |
| Core i7 | 2600S | 4 | Yes | 2.8 GHz | 3.8 GHz | 8 MB | 65W | HD 2000 | 850~1100 MHz |
| | 2600 | 4 | Yes | 3.4 GHz | 3.8 GHz | 8 MB | 95W | HD 2000 | 850~1350 MHz |
| | 2600K | 4 | Yes | 3.4 GHz | 3.8 GHz | 8 MB | 95W | HD 3000 | 850~1350 MHz |
| | 2700K | 4 | Yes | 3.5 GHz | 3.9 GHz | 8 MB | 95W | HD 3000 | 850~1350 MHz |

K = unlocked, S = Performance optimized lifestyle, T = Power optimized lifestyle, HT = Hyper Threading

Intel HD graphics HD 3000/2000 supports 12/6 Execution Units (Shader-Quads) and DirectX 10.1

HDMI 1.4a is only supported with 2nd Intel® Generation Core(TM) i3/i5/i7 Processors. Pentium and Celeron Processors support HDMI 1.3.

Note: Intel® H67 Express Chipset does not enable overclocking features of unlocked 2nd generation Intel Core processor family (K series: Core i5-2500K and Core i7-2600K/2700K).

Certain processor models do not include the integrated graphics, e.g. Intel Core i5-2380P, Core i5-2450P and Core i5-2550K.

Please refer to the support list for detailed processor support information at global.shuttle.com.

Shuttle XPC Barebone SH67H7 Specifications

| | |
|-------------------------------------|--|
| <p><i>H7-Chassis</i></p> | <p>Black aluminum chassis Storage bays: 1 x 5.25" (external), 2 x 3.5" (1x internal, 1x external) Front door for I/O ports and storage drives Dimensions: 32.5 x 20.8 x 18.9/19.6 cm (LWH) without/with rubber feet Weight: 3.6 kg net / 5.0 kg gross</p> |
| <p><i>Mainboard and Chipset</i></p> | <p>Shuttle FH67, Shuttle form factor, proprietary design for XPC SH67H7 Chipset/Southbridge: Intel® H67 Express (Codename: Cougar Point) Platform Controller Hub (PCH) as Single-Chip-Solution Passive chipset cooling with heat sink The Northbridge is integrated into the processor. Solid Capacitors for sensitive areas provide excellent heat resistance for enhanced system durability</p> |
| <p><i>BIOS</i></p> | <p>AMI BIOS, SPI Interface, 32MBit Flash-ROM Supports PnP, ACPI 3.0, Hardware Monitoring Supports Unified Extensible Firmware Interface (UEFI)*** Supports boot up from external USB flash memory</p> |
| <p><i>Power Supply</i></p> | <p>300 Watt mini PSU, AC input voltage: 100~240V 80 PLUS® certified (80% or greater energy-efficient) Active PFC circuit (Power Factor Correction) ATX main power connectors: 2x10 and 2x2 pins Graphics power connector: 6 pins</p> |
| <p><i>Processor Support</i></p> | <p>Socket 1155 (LGA 1155) supports next generation of Intel Core i3 / i5 / i7 desktop processors with up to 95W TDP Not compatible with older Socket-1156 processors. The Processor integrates PCI-Express, memory controller and an optional graphics engine on the same die Please refer to the support list for detailed processor support information at global.shuttle.com.</p> |
| <p><i>Processor Cooling</i></p> | <p>Shuttle I.C.E. (Integrated Cooling Engine) advanced I.C.E. Heatpipe technology, linear controlled 92mm fan SilentX cooling and noise reduction technology with Active Airflow</p> |
| <p><i>Memory Support</i></p> | <p>4 x 240 pin slots Supports DDR3-1066/1333 SDRAM memory (PC3-8500/10600) Supports 2+2 Dual Channel mode Supports max. 8 GB per DIMM, maximum total size of 32 GB</p> |

| | |
|--|---|
| <p><i>Optional: Integrated graphics</i></p> | <p>Intel® HD Graphics 2000/3000 integrated in the processor Supports Pixel Shader 4.1, DirectX 10.1 Maximum shared memory size: 1692MB Intel® HD Graphics 2000/3000 integrated in the processor Supports Pixel Shader 4.1, DirectX 10.1 Maximum shared memory size: 1692MB Supports HDMI 1.4a, max. resolution up to 1920x1200 @ 60Hz Supports DVI, max. resolution up to 1920x1200 @ 60Hz Supports D-Sub, max. resolution up to 2048x1536 @ 75Hz (optional VGA-to-DVI-adapter required) Supports Blu-ray Stereoscopic 3D with HDMI 1.4a Supports HDCP function with DVI and HDMI ports Supports Full HD 1080p Blu-ray (BD) / HD-DVD playback with DVI and HDMI ports Supports Dual-Independent-Display via HDMI and DVI-I port **) HDMI supports HD-video plus multi-channel digital audio on a single cable Note: Certain processor models do not include the integrated graphics, e.g. Intel Core i5-2380P, Core i5-2450P and Core i5-2550K.</p> |
| <p><i>Expansion Slots</i></p> | <p>1x PCI-Express x16 v2.0 slot (PEG, for graphics cards only) 1x PCI-Express x1 v2.0 slot 1x Mini-PCI-Express x1 v2.0 slot (for the optional WLAN module) Supports Dual-slot (double-width) graphics cards - in this case the second PCI-Express slot will be occupied. A 6 pin power connector is available for the graphics card.</p> |
| <p><i>8-channel Audio</i></p> | <p>7.1 channel High Definition Audio with Realtek ALC888 codec Azalia standard support Analog: line-out (7.1-ch), line-in, microphone, AUX input (onboard) Digital: optical S/PDIF-out (Digital Audio also via HDMI output)</p> |
| <p><i>Gigabit-LAN Controller</i></p> | <p>Realtek RTL 8111E Ethernet network controller PCI Express interface IEEE 802.3u 1000Base-T compliant Supports 10 / 100 / 1.000 MBit/s operation Supports Wake-on-LAN (WOL)</p> |
| <p><i>Drive connectors</i></p> | <p>2x Serial ATA rev. 3.0, max. 6 Gbit/s (onboard) 2x Serial ATA rev. 2.0, max. 3 Gbit/s (onboard) 2x External Serial ATA rev. 2.0, max. 3 Gbit/s (1x front, 1x rear) Supports Intel Rapid Storage Technology (Raid 0/1/5/10, JBOD)</p> |
| <p><i>Front panel connectors and buttons</i></p> | <p>Microphone input Headphone output 2x USB 3.0 External Serial ATA 3 Gb/s (eSATA) + USB 2.0 Combo Power button Power indicator (LED) Hard disk drive indicator (LED) Reset button</p> |

©2011 by Shuttle Computer Handels GmbH (Germany). All information is subject to change without notice. Pictures for illustration purposes only.

| | |
|--|--|
| <p><i>Back panel connectors</i></p> | <p>HDMI rev. 1.3 (supports digital audio) **) DVI-I (supports analog VGA with optional adapter) **) 4x USB 2.0 2x USB 3.0 GigaBit LAN (RJ45) 8-ch Audio line-out (2x rear/front, bass/center, surround/back) Audio Line-in External Serial ATA (eSATA 3Gb/s) Digital Audio: optical S/PDIF output Clear CMOS button optional: Serial port (RS-232)</p> |
| <p><i>Other connectors (onboard)</i></p> | <p>2x USB 2.0 (one set with 2x5 pins) 1x RS232 (2x5 pins) 2x fan connectors (4 pins and 3 pins) Audio AUX input CIR/Infrared (1x3 pins) GPIO (1x5 pins)</p> |
| <p><i>Included Accessories</i></p> | <p>Multilanguage XPC Installation Guide 32/64bit driver disk Preinstalled cables: 2x SATA Power Cord Screws Heatsink Compound</p> |
| <p><i>Optional Accessories</i></p> | <p>Backpanel COM port adapter for the RS232 serial interface Wireless LAN Modul 802.11n (Mini-PCIe card) 500W Power supply (80Plus Bronze)</p> |
| <p><i>Certifications Compliance</i></p> | <p>EMI: FCC, CE, BSMI, C-Tick Safety: ETL, CB, BSMI, TÜV Other: Windows 7 Premium Logo, RoHS, Eup Lot6, Energy Star</p> |

***) Overclocking Warning**

Please note there is a certain risk involved with overclocking, including adjusting the setting in the BIOS or using third-party overclocking tools. Overclocking may affect your system stability or even cause damage of the components and devices of your system. It is done at your own risk and expense. Shuttle cannot be held responsible for possible damage caused by overclocking. Intel® H67 Express Chipset does not enable overclocking features of unlocked 2nd generation Intel Core processor family (K series: Core i5-2500K and Core i7-2600K).

****)** the video outputs (HDMI und DVI-I) cannot be used, if the processor does not integrate a graphics function, e.g. Intel Core i5-2380P, Core i5-2450P and Core i5-2550K.

HDMI 1.4a is only supported with 2nd Intel® Generation Core(TM) i3/i5/i7 Processors. Pentium and Celeron Processors support HDMI 1.3.

*****)** The Unified Extensible Firmware Interface (UEFI) is required when booting from hard disks larger than 2.2 TB under Windows 64 bit operating systems such as Windows 7, Windows Vista SP1 and Windows Server 2008/2003 SP1.

Shuttle XPC Barebone SH67H7 – Connectors

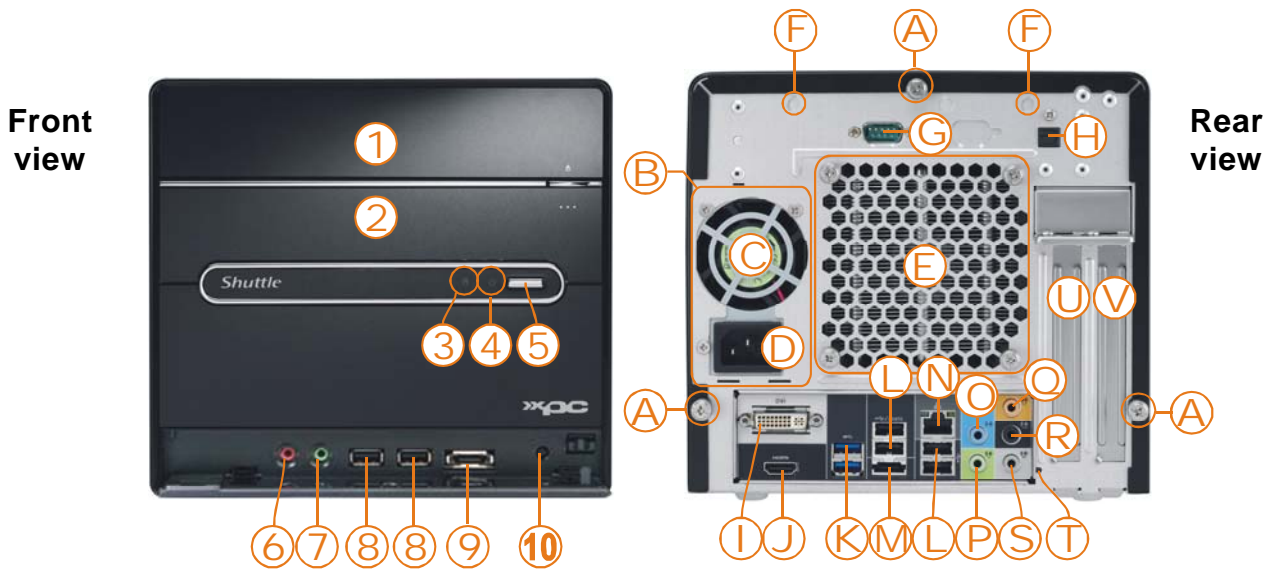

- | | | | | | |
|----|---------------------------------|---|--------------------------------------|---|----------------------|
| 1 | 5.25" bay for the optical drive | A | Three thumbscrews | K | 2x USB 3.0 |
| 2 | 3.5" bay | B | Power supply | L | 4x USB 2.0 |
| 3 | Hard disk LED indicator | C | Power supply fan | M | External Serial-ATA |
| 4 | Power LED indicator | D | AC power connector | N | Gigabit LAN (RJ45) |
| 5 | Power button | E | Heat-pipe cooling system | O | Audio Line-in |
| 6 | Headphone output | F | Perforation for optional WLAN module | P | Audio Surround Front |
| 7 | Microphone input | G | COM / RS232 (optional) | Q | Audio Center/Bass |
| 8 | 2x USB 3.0 ports | H | Dig. S/PDIF audio output | R | Audio Surround Rear |
| 9 | eSATA+USB combo port | I | DVI-I video output *) | S | Audio Surround Side |
| 10 | Reset button | J | HDMI video output *) | T | Clear-CMOS-Button |
| | | | | U | PCI-Express X16 slot |
| | | | | V | PCI-Express X1 slot |

*) Remark:: The integrated video outputs (HDMI and DVI-I) cannot be used, if the processor does not integrate a graphics function, e.g. Intel Core i5-2380P, Core i5-2450P and Core i5-2550K.

