



Hardware Calibration LCD Monitors

ColorEdge Series

Color as it's meant to be



ColorEdge — perfect color results for your digital workflow

Choosing the right monitors for a color management system

The Importance of Color Management

In today's digital production environment, there are many opportunities for discrepancies in color to arise along the path from the computer to the printer. This is because input devices (cameras, scanners, etc.), display devices (monitors) and output devices (various kinds of printers) may all be set to different color spaces. Such discrepancies can be avoided by employing a color management system that ensures every device in the production chain is set to a common color space.

Color Management Begins with the Monitor

The monitor is the core of any professional color management system. If color is displayed accurately on the monitor, and color matching has been done with the output device, then you no longer have to make multiple proofs just to correct for color discrepancies. You can proof with confidence right from the start, while lowering costs, increasing efficiency and improving quality control.

ColorEdge — the Right Monitors for Color Management

Effective color management requires monitors with accurate color reproduction and gradation characteristics. With ColorEdge monitors you get factory-adjusted gamma, extensive hardware calibration capabilities and an exceptionally wide color gamut. Their outstanding performance and reliability make

them ideal for a wide range of professional environments where color reproduction is critical, including photography, graphics, printing and publishing.

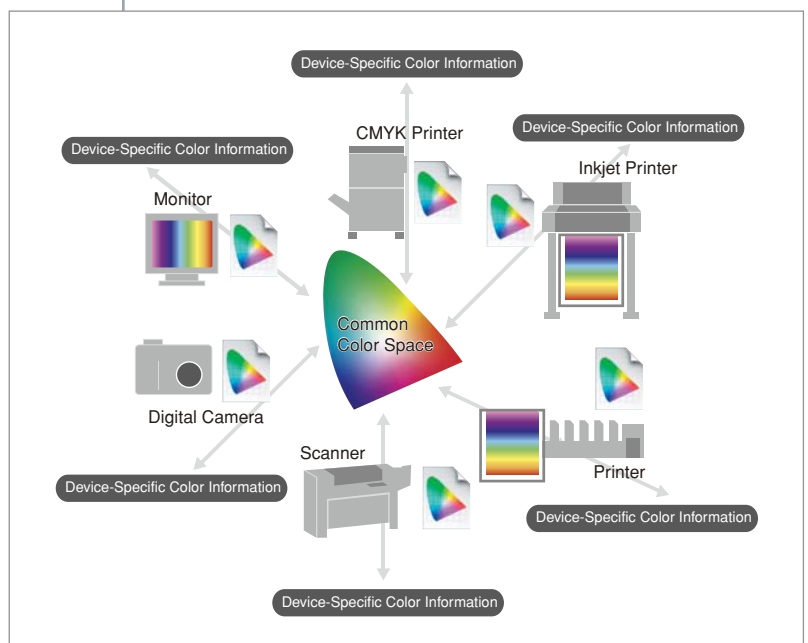



Adobe RGB color space reproduction — connecting the photographer, designer, and printer

Soft Proofing with Adobe RGB

The benefits of color management quickly become apparent once a system is put into place. When all devices share a common color space, colors match at every stage of production; knowing that color is being accurately displayed naturally improves efficiency. A wide-gamut ColorEdge monitor at the

center of a system using Adobe RGB as the common color space is the ideal way to ensure accurate color reproduction across all digital platforms. Such a color management environment fully supports soft proofing at every step of production, from initial photography to final printing.

Wide Color Gamut Monitors

With a wide color gamut that reproduces nearly 100% of the Adobe RGB color space, these monitors not only cover the sRGB color space supported by many computer monitors, operating systems and digital cameras, but practically the entire ISO-coated and US web-coated CMYK color spaces used in printing as well.

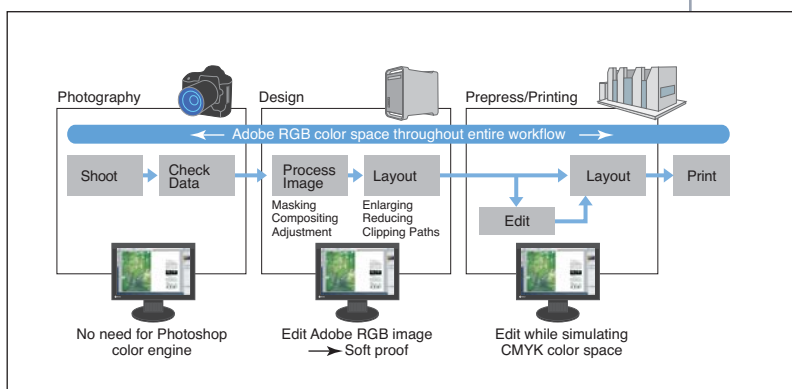
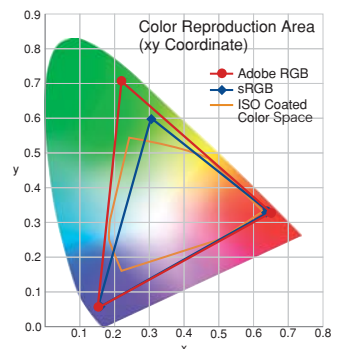

Consummate Performance and Functionality

Factory Adjustment of Gamma

The gamma level for each ColorEdge monitor is adjusted at the factory. This is accomplished by measuring the R, G, and B gamma values from 0 – 255, then using the monitor's 16-bit look-up table (LUT) to select the 256 most appropriate tones to achieve the desired value.



Each monitor adjusted individually at the factory. (For illustrative purposes only. Actual adjustment is performed in a darkroom.)

This is important because accurate, non-fluctuating gamma values are necessary for the proper display of color. If colors are not based on specific values and cannot be adjusted, images will be displayed differently by different monitors. ColorEdge monitors provide both precision and consistency, so graphics professionals can be sure that the final product will look exactly the way they want it to. In fact, each monitor comes with an adjustment certificate that certifies the measurement results of the gamma value.

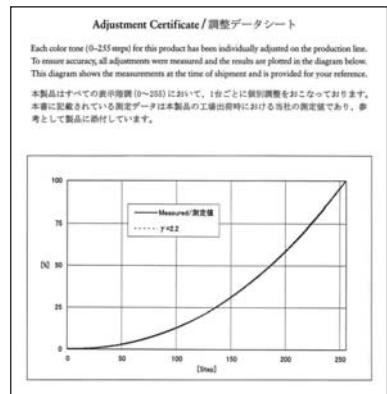
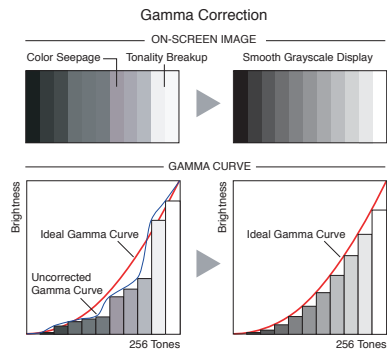

Brightness and Color Uniformity with DUE

Fluctuations in brightness and chroma on different parts of the screen are a common trait of LCD monitors. To counteract this, EIZO incorporates a Digital Uniformity Equalizer (DUE) in all ColorEdge monitors. DUE utilizes the monitor's 16-bit look-up table (LUT) with an extensive palette of 65,281 grayscale tones for each R, G, and B to ensure a Delta-E difference of 3 or less across the screen when the monitor leaves the factory.*

*Delta-E difference for the CG303W is 5 or less along the screen perimeter.

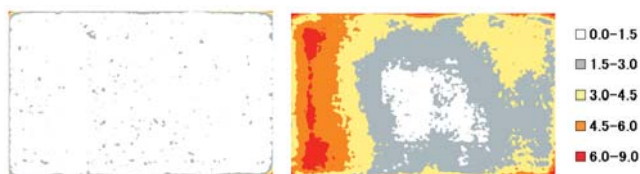

Color-separated image with Delta-E*ab distribution across the screen of the ColorEdge CG221 (gray level 128 measured)

16-Bit LUT, 10-Bit Simultaneous Display

Most ColorEdge monitors offer 10-bit simultaneous color display* from a 16-bit look-up table which means they can show more than one billion colors simultaneously. This is 64 times as many colors as you get with 8-bit display which results in even smoother color gradations and reduced Delta-E between two adjacent colors.

*A graphics board and software which support 10-bit output are also necessary for 10-bit display.

8-bit and 10-bit image display

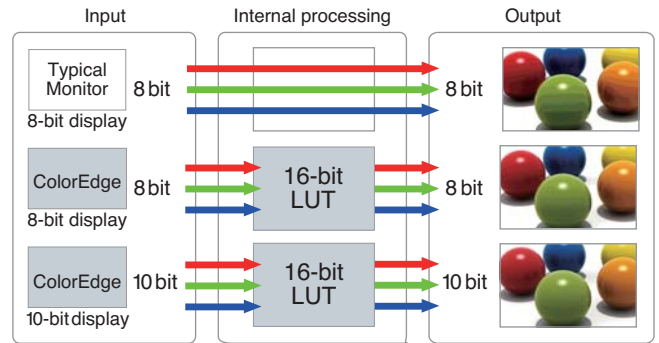

3D LUT for Better Additive Color Mixture

All ColorEdge models incorporate a look-up table (LUT) for accurate color and grayscale rendering, but the ColorEdge CG275W, CG245W, CG243W, and CG223W utilize an EIZO-developed 3D LUT. Whereas a typical 1D LUT adjusts color on separate tables for each red, green, and blue, a 3D LUT accomplishes this on a single, mixed-color cubic table. A 3D LUT improves the monitor's additive color mixture (combination of RGB), a key factor in its ability to display neutral gray tones.

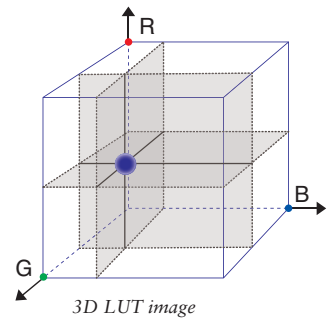

Predictable Color with Any Media

With content published on so many different types of printed and digital media it's critical to know how your clients will see color. A ColorEdge monitor and the bundled ColorNavigator software let you do just that as they are designed for both softproofing and digital device emulation. So now you can "predict" how color will appear to your clients whether you produce content for printed media like books and magazines or for digital media devices like tablets, smart phones, and notebook computers.

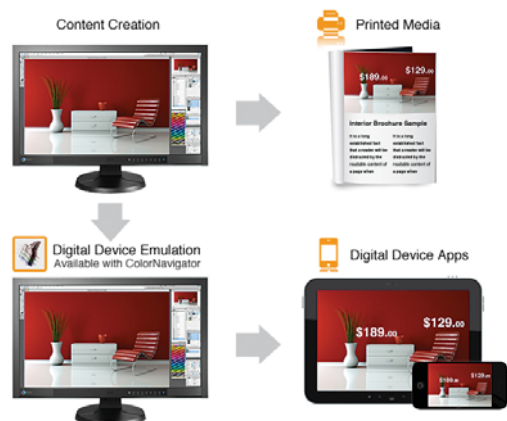

Extensive Calibration Capabilities

Simple and Precise Calibration

The EIZO-developed ColorNavigator software makes calibration both simple and accurate. Instead of having to judge colors and do time-consuming inputting, or having a specialist do it for you, all you need to do is input target values for brightness, white point and gamma. ColorNavigator works with a wide range of measurement devices to directly utilize the 16-bit LUT of ColorEdge monitors for accurate and reliable calibration in minutes. The latest version of ColorNavigator is always available as a free download at www.eizo.com.



Industry's First Self-Calibrating Monitors

The ColorEdge CG245W and CG275W come with an industry-first built-in calibration sensor. The sensor is housed within the monitor's bezel and swings out only when calibrating. This eliminates the need for an external sensor, lets you calibrate when your computer is off, and saves time by letting you schedule the monitor to self-calibrate while you are not working. To ensure predictable and accurate calibration across the screen, EIZO calibrates the center of the screen at its factory and correlates the built-in sensor to these results. Furthermore, if you are working with other ColorEdge monitors and need to standardize calibration, you can use the bundled ColorNavigator software to correlate the calibration results of the built-in sensor to the results obtained from an external calibration device.



ColorEdge CG245W built-in sensor

Paper White Measurement

ColorNavigator offers a paper white measurement function for color matching between the image on your monitor and the image on your printouts. By measuring the white of the paper to be used for printing, ColorNavigator will automatically set the target values for brightness and white point accordingly.

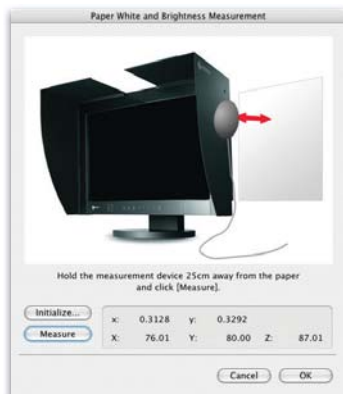

Light Box Brightness Adjustment

With ColorNavigator and a measurement device, you can set your light box's* brightness to the desired value. ColorNavigator can then take the resulting brightness level and set it as the monitor's target calibration value to ensure uniform brightness between your monitor and light box when color proofing.

*Currently supports JUST Color Communicator 1 and 2 only.

Profile Validation

This function measures the monitor's color patches to determine the difference between the Delta-E value of the monitor's profile and the actual displayed values of the monitor. This allows for verifying the results of calibration or checking to see how much the monitor's colors have varied since it was last calibrated. ColorNavigator can also measure CMYK color patches (GRACoL 2006 Coated #1 and FOGRA39) and output them as Adobe Photoshop or Acrobat files.* The measurement results of both the monitor and profile for each color patch are indicated in either CIELAB or XYZ values, and the difference between them expressed in Delta-E. The Delta-E variation can be shown in a graph and compared with previous results. ColorNavigator even exports profile validation results as a PDF for easy distribution among work sites, printers, or clients.



*Photoshop CS1 or later or Acrobat Professional 7 or later are required for Macintosh, and Photoshop CS1 or later or Acrobat Professional 8 or later are required for Windows.

Post-Calibration Color Adjustment

Sometimes due to variations in output from different printers or the special requirements of a project, it is necessary to fine-tune an otherwise perfectly calibrated monitor to match target colors. ColorNavigator lets you easily adjust hue and saturation for all six primary and secondary colors (RGB and CMY), as well as white balance, brightness, black level and gamma, to achieve the closest possible visual match. For confirmation of calibration results or to achieve more accurate manual adjustments, a test pattern screen with a grayscale ramp, low tones, high tones and gamma values can be displayed.



ColorNavigator Compatible Measurement Devices

- X-Rite: Eye-One Series, ColorMunki*, DTP94, DTP94B
- DataColor: Spyder 2, Spyder 3

*ColorMunki Create is not compatible.

ColorNavigator Compatible Operating Systems

Compatible Operating Systems*	Macintosh	Windows
	OS X 10.4 - 10.6	7 (32/64-bit), Vista (32/64-bit), XP (32/64-bit)

*A version of ColorNavigator with Mac OS X 10.3.9 compatibility for the CG303W, CG243W, CG241W, CG223W, and CG221 is available on www.eizo.com.

Specifications



ColorEdge CG303W



ColorEdge CG275W



ColorEdge CG245W

Panel Size	29.8" / 76 cm (756 mm diagonal)	27" / 68 cm (684 mm diagonal)	24.1" / 61 cm (611 mm diagonal)
Viewing Angles (H, V)	178°, 178° (at contrast ratio of 10:1)	178°, 178° (at 10:1 contrast ratio)	178°, 178° (at contrast ratio of 10:1)
Panel Type	IPS	IPS (with overdrive circuit)	IPS (with overdrive circuit)
Brightness	260 cd/m ² (maximum) 120 cd/m ² or less (recommended ¹)	270 cd/m ² (maximum) 120 cd/m ² or less (recommended ¹)	270 cd/m ² (maximum) 120 cd/m ² or less (recommended ¹)
Contrast	850:1	850:1	850:1
Response Time (Typical)	Black-white-black: 12 ms	Gray-to-gray 6 ms, black-white-black 12 ms	Gray-to-gray: 5 ms, black-white-black: 13 ms
Native Resolution	Signal 1: 2560 × 1600; Signal 2: 1920 × 1200	2560 × 1440	1920 × 1200
Pixel Pitch	0.2505 × 0.2505 mm	0.2331 × 0.2331 mm	0.270 × 0.270 mm
Display Colors (Maximum)	DVI (8 bit): 16.77 million from a palette of 278 trillion DisplayPort (10 bit): 1.07 billion from a palette of 278 trillion	1.07 billion from a palette of 278 trillion	DVI: 16.77 million from a palette of 278 trillion DisplayPort: 1.07 billion from a palette of 278 trillion
Wide Gamut Coverage	Adobe RGB: 98%, sRGB: 100%	Adobe RGB 97%, sRGB: 100%	Adobe RGB: 98%, sRGB: 100%
Look-Up Table Bit Depth	16 bits per color	16 bits per color	16 bits per color
3D Look-Up Table	–	Yes	Yes
Screen Uniformity ¹	Center: ΔE≤3, Perimeter: ΔE≤5	Entire Screen ΔE≤3	Entire Screen: ΔE≤3
Dot Clock	269 MHz	242 MHz	Analog: 170 MHz, Digital: 164.5 MHz
Analog Scanning Frequency (H, V)	–	–	24 – 76 kHz, 47.5 – 86 Hz
Digital Scanning Frequency (H, V)	26 – 100 kHz, 29.5 – 30.5 Hz/59 – 61 Hz (VGA Text: 69 – 71 Hz)	26 – 89 kHz, 23.75 – 63 Hz (VGA Text 69 – 71 Hz)	26 – 78 kHz, 23.75 – 63 Hz (VGA Text: 69 – 71 Hz)
Video Input Terminals	DVI-D 24 pin × 2 (dual link × 1, single link × 1 [with HDCP])	DisplayPort × 1 (with HDCP), Mini DisplayPort × 1 (with HDCP), DVI-D 24 pin × 1 (with HDCP)	DVI-I 29 pin × 2 (with HDCP), DisplayPort (with HDCP)
USB Ports / Standard	1 upstream, 2 downstream / USB 2.0	1 upstream, 2 downstream / USB 2.0	1 upstream, 2 downstream / USB 2.0
Power Requirements	AC 100 – 120 V / 200 – 240 V, 50 / 60 Hz	AC 100 – 120 V / 200 – 240 V, 50 / 60 Hz	AC 100 – 120 V / 200 – 240 V, 50 / 60 Hz
Power Consumption	170 W (maximum), 81 W (typical)	160 W (maximum), 64 W (typical)	100 W (maximum), 48 W (typical)
Power Save Mode	Less than 1.5 W	Less than 1 W	Less than 1 W
Height Adjustment Range	118 mm	151.5 mm (maximum 190 mm)	157 mm
Tilt / Swivel / Pivot	40° Up, 0° Down / 35° Right, 35° Left / 90°	25° Up, 0° Down / 172° Right, 172° Left / 90°	30° Up, 0° Down / 172° Right, 172° Left / 90°
Dimensions (W × H × D)	With Stand: 689 × 511.5 – 629.5 × 254.7 mm; Without Stand: 689 × 450 × 90 mm	With Stand: 646 × 425 – 576.5 × 281.5 mm; Without Stand: 646 × 402 × 92 mm	With Stand: 566 × 396.5 – 553.5 × 242 – 256 mm; Without Stand: 566 × 382 × 92.5 mm
Net Weight	With Stand: 16.1 kg Without Stand: 11.6 kg	With Stand: 13.6 kg Without Stand: 9.7 kg	With Stand: 10.1 kg Without Stand: 7.1 kg
Preset Modes	Fine Contrast (Custom, sRGB, Calibration, Emulation)	Color Mode (Custom, Adobe RGB, sRGB, Rec709, EBU, SMPTE-C, DCI, Calibration)	Color Mode (Custom, Adobe RGB, sRGB, Rec709, EBU, SMPTE-C, DCI, Calibration)
Supplied Accessories	AC power cord, signal cables (DVI-D – DVI-D, DVI-D – DVI-D [dual link supported]), USB cable, setup guide, EIZO LCD Utility Disk (ColorNavigator software, PDF user's manual), adjustment certificate, ScreenCleaner, monitor hood, quick reference, warranty card	AC power cord, signal cable (DVI-D – DVI-D [dual link supported]), Mini DisplayPort – DisplayPort), USB cable, setup guide, EIZO LCD Utility Disk (ColorNavigator software, PDF user's manual), adjustment certificate, ScreenCleaner, monitor hood, quick reference	AC power cord, signal cables (DVI-D – DVI-D, DisplayPort – DisplayPort), USB cable, setup guide, EIZO LCD Utility Disk (ColorNavigator software, PDF user's manual), adjustment certificate, ScreenCleaner, monitor hood, quick reference, warranty card
Warranty	Five Years ²	Five Years ²	Five Years ²

¹ Measured at gray level 128 and color temperature of 5000 K. ² The usage time is limited to 30,000 hours and the warranty period of the LCD panel is limited to three years from the date of purchase. The warranty period of the backlight is warranted only if it is used within the recommended brightness of up to and including 100 cd/m² for the CG221 and 120 cd/m² for the CG303W, CG275W, CG245W, CG243W, CG241W, and CG223W with the color temperature for the aforementioned models between 5,000 K – 6,500 K and limited to three years from the date of purchase subject to the usage time being less than or equal to 10,000 hours.
All ColorEdge monitors meet the ISO9241-307 (Pixel fault class I) standard. With current LCD technology, a panel may contain a limited number of missing or flickering pixels.

Accessories

Monitor Hoods

Bundled with all models, EIZO's monitor hoods include a sliding top cover so they can remain in place when the monitor is calibrated. With the CG275W and CG245W, the hood can be used in portrait mode, too.

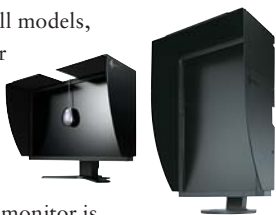

Panel Protectors

These protection sheets are easy to place over the screen surface, allow a minimum of 87% light transmission, and prevent dust and scratches. (Available for the CG243W, CG241W, and CG223W. Sold separately.)



Screen Cleaner Kit

Keep your screen free from dust and fingerprints with this bundled screen cleaner kit. Includes pump spray and cloth.





ColorEdge CG243W



ColorEdge CG241W



ColorEdge CG223W



ColorEdge CG221

24.1" / 61 cm (611 mm diagonal)	24.1" / 61 cm (611 mm diagonal)	22" / 56 cm (558 mm diagonal)	22.2" / 56.4 cm (563 mm diagonal)
178°, 178° (at contrast ratio of 10:1)	178°, 178° (at contrast ratio of 10:1)	178°, 178° (at contrast ratio of 10:1)	170°, 170° (at contrast ratio of 10:1)
IPS (with overdrive circuit)	VA (with overdrive circuit)	VA (with overdrive circuit)	IPS
270 cd/m ² (maximum) 120 cd/m ² or less (recommended ¹)	300 cd/m ² (maximum) 120 cd/m ² or less (recommended ¹)	270 cd/m ² (maximum) 120 cd/m ² or less (recommended ¹)	200 cd/m ² (maximum) 100 cd/m ² or less (recommended ¹)
850:1	850:1	950:1	400:1
Gray-to-gray: 5 ms, black-white-black: 13 ms	Gray-to-gray: 6 ms, black-white-black: 16 ms	Gray-to-gray: 6 ms, black-white-black: 12 ms	Gray-to-gray: -, black-white-black: 30 ms
1920 × 1200 (16:10 aspect ratio)	1920 × 1200 (16:10 aspect ratio)	1680 × 1050 (16:10 aspect ratio)	1920 × 1200 (16:10 aspect ratio)
0.270 × 0.270 mm	0.270 × 0.270 mm	0.282 × 0.282 mm	0.249 × 0.249 mm
DVI: 16.77 million from a palette of 278 trillion DisplayPort: 1.07 billion from a palette of 278 trillion	16.77 million from a palette of 278 trillion	DVI: 16.77 million from a palette of 278 trillion; DisplayPort: 1.07 billion from a palette of 278 trillion	16.77 million from a palette of 278 trillion
Adobe RGB: 98%, sRGB: 100%	Adobe RGB: 96%, sRGB: 98%	Adobe RGB: 95%, sRGB: 98%	Adobe RGB: 98%, sRGB 98%
16 bits per color	16 bits per color	16 bits per color	16 bits per color
Yes	-	Yes	-
Entire Screen: ΔE≤3	Entire Screen: ΔE≤3	Entire Screen: ΔE≤3	Entire Screen: ΔE≤3
Analog: 170 MHz, Digital: 164.5 MHz	Analog: 202.5 MHz, Digital: 164.5 MHz	Analog: 150 MHz, Digital: 120 MHz	Analog: 202.5 MHz, Digital: 162 MHz
24 – 76 kHz, 47.5 – 86 Hz	24 – 94 kHz, 47.5 – 86 Hz	24 – 82 kHz, 47.5 – 86 Hz	31 – 94 kHz, 49 – 86 Hz
26 – 78 kHz, 23.75 – 63 Hz (VGA Text: 69 – 71 Hz)	26 – 78 kHz, 47.5 – 63 Hz (VGA Text: 69 – 71 Hz)	31 – 65 kHz, 47.5 – 61 Hz (VGA Text: 69 – 71 Hz)	31 – 76 kHz, 59 – 61 Hz (VGA Text: 69 – 71 Hz)
DVI-I 29 pin × 2 (with HDCP), DisplayPort (with HDCP)	DVI-I 29 pin × 2 (with HDCP)	DVI-I 29 pin × 2 (with HDCP), DisplayPort (with HDCP)	DVI-I 29 × 2
1 upstream, 2 downstream / USB 2.0	1 upstream, 2 downstream / USB 2.0	1 upstream, 2 downstream / USB 2.0	1 upstream, 2 downstream / USB 2.0
AC 100 – 120 V / 200 – 240 V, 50 / 60 Hz	AC 100 – 120 V / 200 – 240 V, 50 / 60 Hz	AC 100 – 120 V / 200 – 240 V, 50 / 60 Hz	AC 100 – 120 V / 200 – 240 V, 50 / 60 Hz
95 W (maximum), 48 W (typical)	110 W (maximum)	85 W (maximum), 39 W (typical)	100 W (maximum)
Less than 0.9 W	Less than 2 W	Less than 0.9 W	Less than 2 W
157 mm	82 mm	74 mm	100 mm
40° Up, 0° Down / 35° Right, 35° Left / 90°	40° Up, 0° Down / 35° Right, 35° Left / 90°	30° Up, 0° Down / 172° Right, 172° Left / 90°	30° Up, 3° Down / 35° Right, 35° Left / -
With Stand: 566 × 381.5 – 538.5 × 242 – 256 Without Stand: 566 × 367 × 85 mm	With Stand: 566 × 456 – 538 × 230 mm Without Stand: 566 × 367 × 85 mm	With Stand: 511 × 347.5 – 521.5 × 240.5 – 256 mm Without Stand: 511 × 333 × 85 mm	With Stand: 565 × 452.5 – 552.5 × 272 mm Without Stand: 565 × 394.5 × 101 mm
With Stand: 10.1 kg Without Stand: 7.1 kg	With Stand: 11 kg Without Stand: 7.4 kg	With Stand: 9.6 kg Without Stand: 6.6 kg	With Stand: 14.5 kg Without Stand: 10.4 kg
Color Mode (Custom, sRGB, Rec709, EBU, SMPTE-C, DCI, Calibration)	Fine Contrast (Custom, sRGB, Calibration, Emulation)	Color Mode (Custom, sRGB, Rec709, EBU, SMPTE-C, DCI, Calibration)	Fine Contrast (sRGB, Custom, Calibration, Emulation)
AC power cord, signal cables (DVI-D – DVI-D, DisplayPort – DisplayPort), USB cable, setup guide, EIZO LCD Utility Disk (ColorNavigator software, PDF user's manual), adjustment certificate, Screen-Cleaner, monitor hood, quick reference, 4 screws for mount option, warranty card	AC power cord, signal cables (DVI-D – DVI-D, DVI-I – D-Sub mini 15 pin), USB cable, setup guide, EIZO LCD Utility Disk (ColorNavigator software, PDF user's manual), adjustment certificate, ScreenCleaner, monitor hood, quick reference, warranty card	AC power cord, signal cables (DVI-D – DVI-D, DisplayPort – DisplayPort), USB cable, setup guide, EIZO LCD Utility Disk (ColorNavigator software, PDF user's manual), adjustment certificate, ScreenCleaner, monitor hood, quick reference, warranty card	AC power cord, signal cables (DVI-D – DVI-D, DVI-I – D-Sub mini 15 pin), USB cable, setup guide, EIZO LCD Utility Disk (ColorNavigator software, HTML user's manual, ICC Profile), adjustment certificate, ScreenCleaner, monitor hood, quick reference, warranty card
Five Years ²	Five Years ²	Five Years ²	Five Years ²

Color Universal Design Feature

Color Vision Deficiency Simulation

To accommodate the more than 200 million people worldwide with a color vision deficiency, care must be taken when choosing color schemes, otherwise important details may not be discernible. These models instantly simulate how still and moving images appear to people with red-



Original mode



Protanope mode



Deuteranope mode



Tritanope mode

green (protanopia and deuteranopia) and blue-yellow (tritanopia) color vision deficiency through internal hardware conversion and EIZO proprietary software. (Compatible with Windows 7, Vista, and XP, and with Macintosh OS X 10.3.9 or later. This feature is not available with the CG221.)

Warranty

Brightness and Color Warranty

EIZO offers a five-year warranty for all ColorEdge monitors. The backlight is warranted for three years at a brightness of up to a specific figure and color temperature from 5,000 – 6,500 K with the usage time a maximum of 10,000 hours. (See footnote 1 on page 6 for brightness figures.)





EIZO NANA O CORPORATION

153 Shimokashiwano, Hakusan, Ishikawa 924-8566 Japan

Phone +81-76-277-6792 Fax: +81-76-277-6793

www.eizo.com

© 2012 Eizo Nanao Corporation

All product names are trademarks or registered trademarks of their respective companies. ColorEdge and EIZO are registered trademarks of Eizo Nanao Corporation. Adobe product screenshots reprinted with permission from Adobe Systems Incorporated. Specifications are subject to change without notice.

Published on chlorine-free paper.

(060907m) Printed in Japan, 3, 2012, 4K

