

# D100 VOICE TRANSCODING CARD

D-Series: Transcoding

**The industry's first affordable PCI or PCI Express voice transcoding card – designed for optimum voice quality for low to high density system, offering 30 to 480 transcoding sessions in one compact 2U form factor!**

IP telephony applications commonly require the use of multiple voice codecs, used to digitally compress voice signals and save on bandwidth. Voice signals from the Public Switched Telephone Network (PSTN) come in the form of the G.711 codec, but the VoIP terminal equipment and networks can support a variety of different voice codecs, such as G.729, G.726, AMR, G.722, iLBC, etc. The VoIP infrastructure needs the capability to mediate between endpoints supporting different codecs, but this functionality requires digital signal processing tasks that are often costly and resource-intensive, and can affect the quality of the voice signals, if it introduces too much latency and delay.



*D100 PCI with low profile bracket*

The D100 card, available in PCI and PCI Express form factors, converts simultaneous channels of transcoding from one type of codec (e.g. G.711) to another (e.g. G.729), without affecting latency or using up precious host CPU resources. The card allows up to 30, 60, 120, 240 or 480 channels of any-to-any voice codec conversion, with unmatched quality<sup>1</sup>. All codecs are fully indemnified; no additional licensing is required for their use<sup>2</sup>.

The D100 works with both Asterisk® and FreeSWITCH™. With compatible drivers, these applications can use the D100 cards as seamless voice transcoding resources.

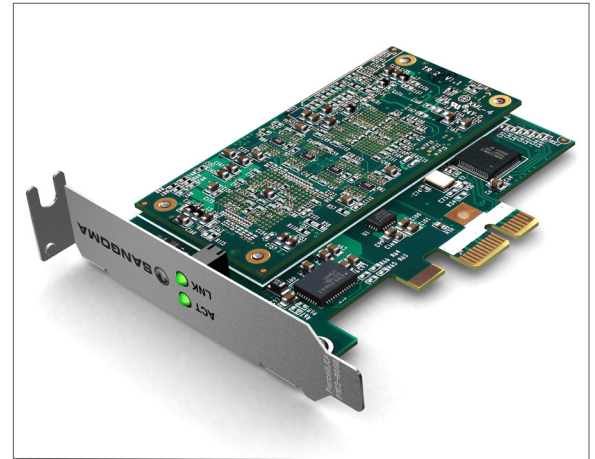

*D100 PCIe with low profile bracket*

## HIGHLIGHTS

- 30 to 480 Transcoding Sessions
- Integrates in Asterisk and FreeSWITCH
- Compact 2U Form Factor
- PCI and PCIe

## CODEC SUPPORT

- G.711
- G.722
- G.722.1
- G.723.1
- G.726
- G.729AB
- iLBC
- GSM-FR
- GMS-EFR
- AMR
- AMR-WB (G.722.2)
- L8 (Linear 8K)
- L16 (Linear 16K)

## SAMPLE APPLICATIONS

- Call Centers and Remote Agent Pools
- Hosted iPBX / IP Centrex
- Distributed PBX
- IP Network Peering
- SIP Trunking
- VoIP Gateways

<sup>1</sup> Total port counts performance varies from codec to codec use and on the traffic mix at any given time.

<sup>2</sup> Except for AMR and AMR-WB

CONTINUE READING »

## TECHNICAL SPECIFICATIONS

### Software

- Support for Asterisk and FreeSWITCH
- Media flows in and out of PCI or PCIe bus

### Dimensions

- Compact factor for use in restricted chassis
- Includes low profile bracket for installation in 2U chassis
- PCI model: 121 mm x 63.5 mm
- PCIe model: 94 mm x 63.5 mm

### Operating Systems

- Linux

### Certifications

- Emissions: FCC Part 15 Class A, CISPR 22, CISPR 24, EN 55022 (pending)

### Bus Supported

- PCI: 32 bit, 33 MHz
- PCIe: x1 bus width, V1.1

### Power Requirements

- PCI: 0.9 A @ 5 V (4.5 W)
- PCIe: 1.35 A @ 3.3 V (4.5 W)

### Operating Temperature Range

- Temperature range: 0 – 50 °C

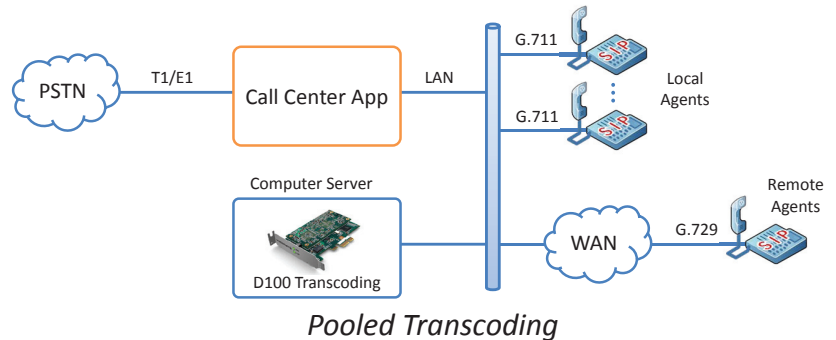
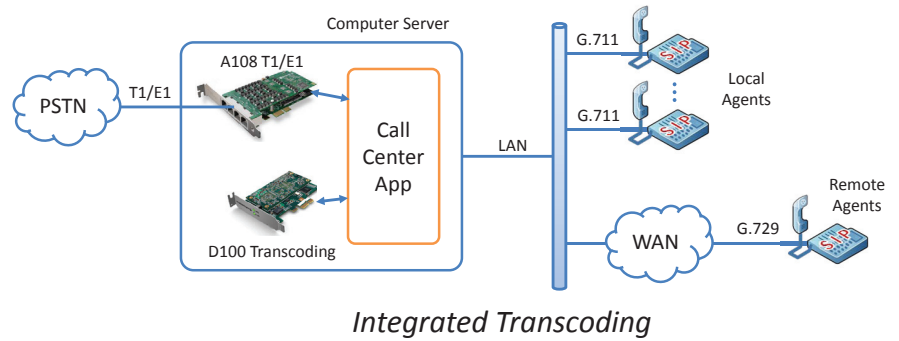

### Production Quality

- ISO 9002

### Warranty

- D-Series hardware comes with a standard 5-year warranty with product registration when purchased through an authorized Empowered by Sangoma representative
- 30-day “no questions asked” return policy

## ORDERING INFORMATION

SKU for PCI Bus	SKU for PCIe Bus	Usage
D100-030	D100-030E	Up to 30 Transcoding Sessions
D100-060	D100-060E	Up to 60 Transcoding Sessions
D100-120	D100-120E	Up to 120 Transcoding Sessions
D100-240	D100-240E	Up to 240 Transcoding Sessions
D100-480	D100-480E	Up to 480 Transcoding Sessions



For more information on how to order, call toll free in North America at **1 800 388 2475**, direct at **+1 905 474 1990** or email [sales@sangoma.com](mailto:sales@sangoma.com).

To purchase now, contact an Empowered by Sangoma Distributor or Reseller near you. Look for the Empowered by Sangoma Logo.